

BOGE AIR. THE AIR TO WORK.



# SCREW COMPRESSORS

OIL-FREE



Over 100,000 compressed air users expect more when it comes to their compressed air supply. **BOGE air provides them with the air to work.**

BOGE oil-free screw compressors have long since proved their importance to compressed air users in critical applications such as pharmaceutical, food and semiconductor industries where absolutely oil-free compressed air is prerequisite.

With a BOGE oil-free screw there is no chance that oil can penetrate the compression process that means oil free air from the start. Oil-free air means less expensive downstream air treatment and moreover these compressors have been engineered for the safe and reliable generation of large quantities of oil-free air, energy efficiently, in base load or intermittent mode.

## **CONTENTS**

<b>OIL-FREE SCREW COMPRESSORS</b>	<b>4</b>
<b>SO SERIES</b>	<b>6</b>

# Clean and efficient compressed air: With BOGE screw compressors.

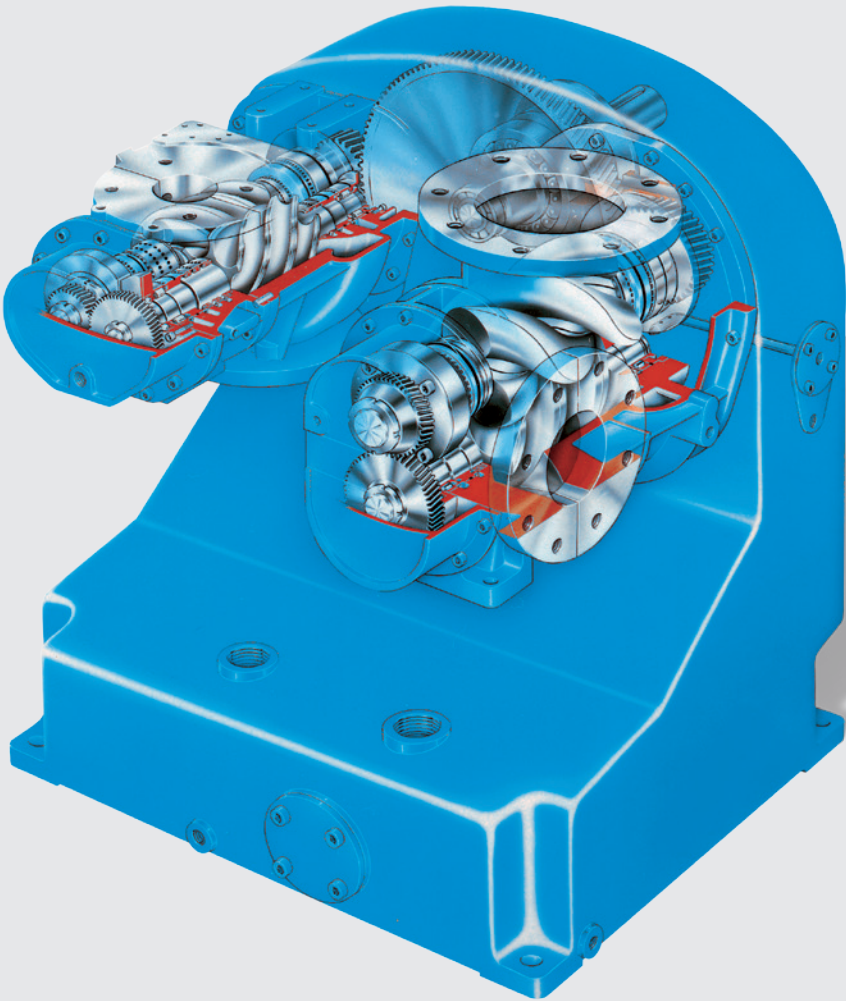

## SOPHISTICATED TECHNOLOGY

Using a two-stage airend ensures very low specific power consumption. The machines are direct driven with frequency control as an option on all compressors.

The shafts are sealed by a combination of special sealing rings and a two-stage labyrinth vented to

atmosphere. This system ensures optimum operational reliability. The precision rotors are finished with a durable coating that prevents corrosion.

The amply dimensioned airend roller bearings are of the highest quality and very durable giving the

most reliable service life even in the most demanding operational conditions. These special bearings eliminate the need for other more traditional means of axial thrust compensation.

**Clean air from the start:** BOGE oil-free screws operate at much higher speeds than oil-injected counterparts and the heat of compression is therefore dissipated differently. The special BOGE airend and the cooling concept are the centrepiece of the design. Both components have been designed to provide utmost safety and maximum efficiency – ideally suited for sensitive fields of application.

## SOPHISTICATED CONCEPT

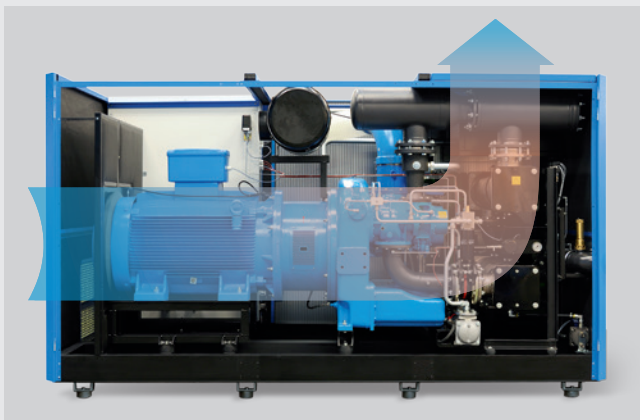

### EFFICIENT COOLING AIR CIRCULATION

BOGE oil-free screw compressors are divided into three clearly defined sections. The component parts are intelligently positioned along the cooling air flow – for increased service life and prompt availability of compressed air. Control electronics, electrical components and motor are located in the coolest part of the machine.

Both airend stages are easily accessible. Because a separate cooling air fan is fitted as standard an optional cowl cooler can be mounted directly on the compressor. As the discharge air is cooled, no additional discharge ducting is required which means the compressor can be installed according to individual requirements

### RELIABLE COOLING CONCEPT

BOGE oil-free screws are available air or water-cooled. A tube in shell principal is used for water cooling. Water flows through the pipes and the compressed air around them, which means that the “dirty” medium passes through the pipes – this facilitates easy maintenance and cleaning. The use of ribbed pipes on the compressed air side and plain pipes on the water-side ensure a high degree of efficiency. Flanged pipes also ensure the replacement of the cooling module without having to remove a single component whereas easily extractable pipe bundles make cleaning in mounted condition simpler than ever. The coolant can be treated to achieve the necessary water quality if required. Where no cooling water is available BOGE can supply a chilling system. Air cooling is possible in many applications which means that a cooling water supply and the associated costs can be totally eliminated.



### Premium Efficiency: IE3 Motors

The S0 series compressors offer the best possible energy efficiency thanks to economical IE3 motors of the premium efficiency class.

# The safe way to generate oil-free compressed air:

## Design advantages of the SO series.

### INTELLIGENT DESIGN

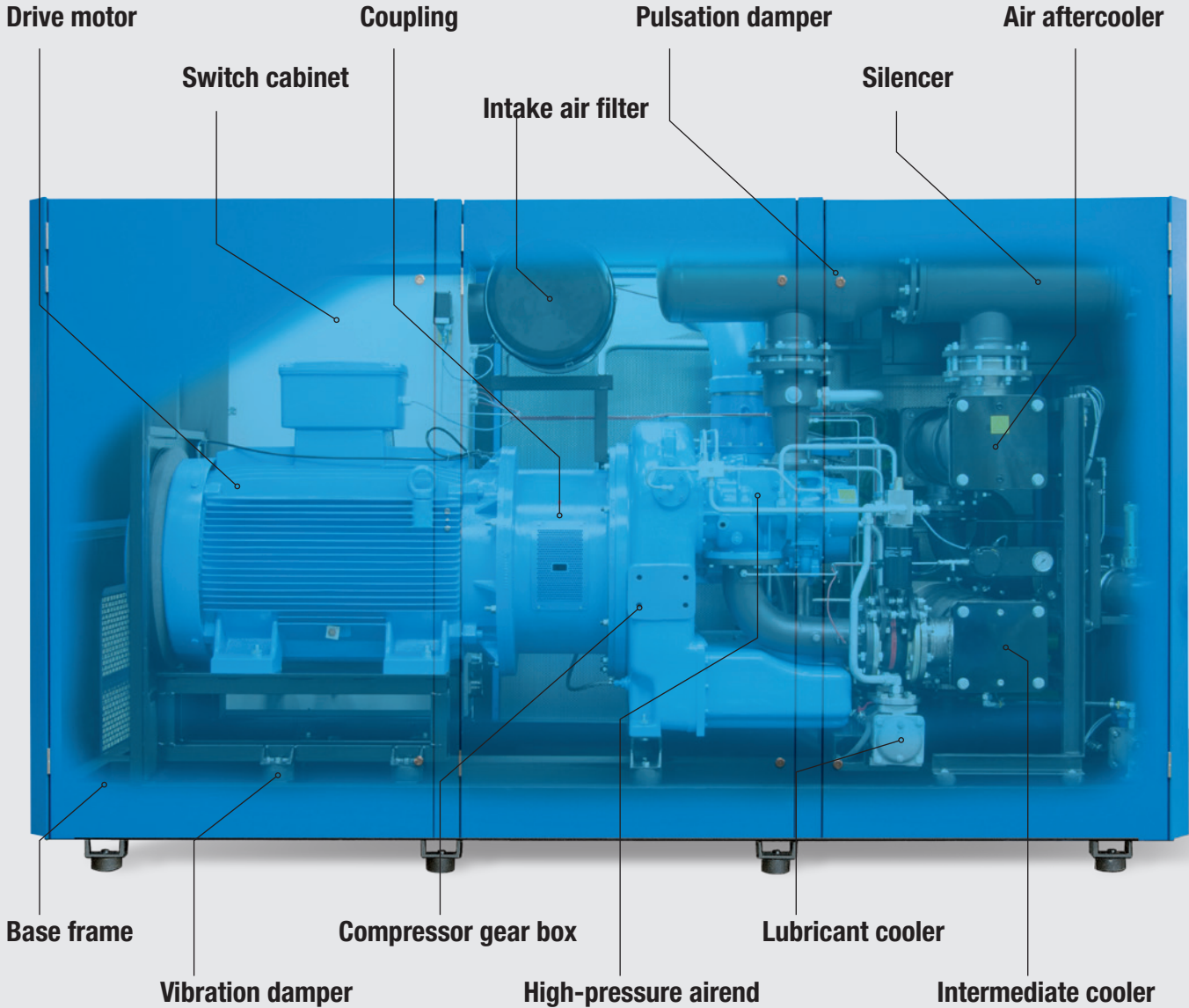

(Example shows water cooled system)

**Precise engineering for clean results:** The SO series is characterised by its intelligent design, innovative functional principle and high quality workmanship. Its dependable quality and high efficiency ensure safe and cost effective generation of oil-free compressed air. Air or water-cooled, fixed or variable speed options are available to suit most every site condition.

## CONVINCING ADVANTAGES

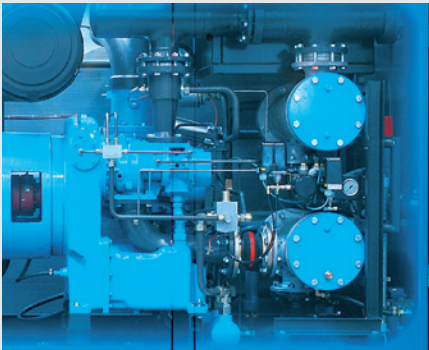

### HIGH QUALITY AND MAINTENANCE FRIENDLY DESIGN

Ease of maintenance was one of the crucial design factors when developing the SO series. All component parts are easily accessible which facilitates prompt and hassle free maintenance. The use of high quality materials and the reduced number of wear parts make the BOGE oil-free screw compressors as efficient and reliable as any demanding customer would expect. The entire production process is subject to permanent quality assurance and is closely monitored by an experienced quality team – from receiving inspection of purchased parts to final inspection and testing.



### FREQUENCY CONTROL (OPTIONAL FEATURE)

The SO series is available with frequency control as an option. It is designed to optimise demand fluctuations enabling a particularly energy efficient operation. The frequency converter is supplied either separately or integrated into the switch cabinet. Part load regulation is then achieved by dynamic speed change. Frequency controlled screw compressors are intended for use as stand-alone machines or ideally suited when covering peak loads in multiple compressor systems with high oil-free compressed air demands.

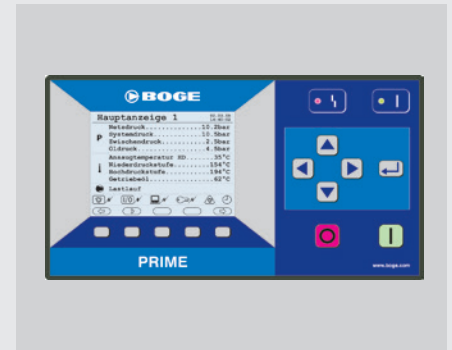

### PRIME COMPRESSOR CONTROL

The PRIME control is the latest state-of-the-art energy efficient controller to come from BOGE. A large-scale back-lit LC display with clear text information shows error/maintenance messages, operating status and all operating parameters on three main menus. Volume flow and pressure characteristics are graphically displayed and freely scalable. The modular design means optional displays – e.g. pressure dew point – can be easily added. The PRIME is fitted with an integral real-time clock and a switch clock function making it possible to control external equipment. Communication is effected via RS 485 interfaces or potential-free contacts.

# SO 61 to SO 126 Oil-free screw compressors (air or water cooled)



Free air delivery: 5.25 – 13.01 m<sup>3</sup>/min, 185 – 459 cfm  
 Pressure range: 8 – 10 bar, 115 – 150 psig  
 Motor range: 45 – 90 kW, 60 – 125 HP

Oil-free compressed  
 air of the highest standard  
 coupled with maximum  
 efficiency and service life!

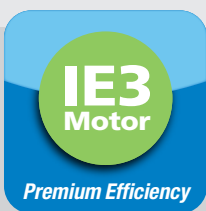

## EFFICIENT DRIVE

All machines in the series come with premium efficiency-class BOGE IE-3 motors. From the moment of initial start-up, these motors save you energy and ensure sustained cost-optimised compressed-air production in the long term.



## EFFICIENT COOLING

A radial fan is used for cowl ventilation. It provides powerful suction, allowing for longer air ducts to be connected. Compared to conventional axial fans, the radial fan saves a good deal of energy and is also smooth-running and quiet.

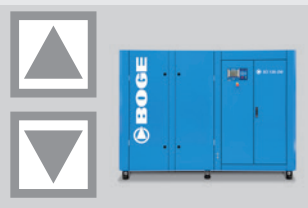

## EFFICIENT OPERATION

All machines in the series are available in a variable-speed version, where the compressor capacity is continually adjusted to actual demands – for the most energy-efficient operation possible. Dynamic speed control achieves infinitely variable part-load control.



## PRIME CONTROL

The PRIME control is the latest state-of-the-art energy efficient controller to come from BOGE. A large-scale back-lit LC display with clear text information shows error/maintenance messages, operating status and all operating parameters on three main menus.



**Oil-free compressed air with efficiency guarantee: This range economically and reliably produces oil-free compressed air. Depending on site requirements they can be air or water cooled. 16 models with 32 variants synchronise the compressed air system to meet your demands.**

BOGE type	max. pressure		free air delivery**				motor power				dimensions silenced	dimensions super silenced	weight silenced	weight super silenced
			(50 Hz)		(60 Hz)		main drive		fan motor		W x D x H	W x D x H	lbs	lbs
			m³/min	cfm	m³/min	cfm	kW	hp	kW	hp	inch	inch		
SO 61 A	8	115	6.65	235.00	6.63	234	45	60	4.77	6.4	114.4x51x74.25	130.4x51x93.9	5851	6468
	10	150	5.25	185.00	5.11	181	45	60	4.77	6.4	114.4x51x74.25	130.4x51x93.9	5851	6468
SO 76 A	8	115	8.86	313.00	8.43	298	55	75	4.77	6.4	114.4x51x74.25	130.4x51x93.9	6182	6799
	10	150	7.70	272.00	7.65	270	55	75	4.77	6.4	114.4x51x74.25	130.4x51x93.9	6182	6799
SO 101 A	8	115	12.06	426.00	11.99	424	75	100	4.77	6.4	114.4x51x74.25	130.4x51x93.9	6468	7086
	10	150	10.46	369.00	9.89	349	75	100	4.77	6.4	114.4x51x74.25	130.4x51x93.9	6468	7086
SO 126 A	8	115	13.01	459.00	13.08	462	90	125	4.77	6.4	114.4x51x77.1	130.4x51x96.8	6715	7333
	10	150	13.01	459.00	12.31	435	90	125	4.77	6.4	114.4x51x77.1	130.4x51x96.8	6715	7333
SO 61 FA	8	115	2.71...6.65	96...235	2.71...6.65	96...235	45	60	4.77*	6.4	114.4x51x74.25	130.4x51x93.9	6292	6909
	10	150	3.45...5.25	122...185	3.45...5.25	122...185	45	60	4.77*	6.4	114.4x51x74.25	130.4x51x93.9	6292	6909
SO 76 FA	8	115	2.93...8.86	104...313	2.93...8.86	104...313	55	75	4.77*	6.4	114.4x51x74.25	130.4x51x93.9	6733	7350
	10	150	3.38...7.70	119...272	3.38...7.70	119...272	55	75	4.77*	6.4	114.4x51x74.25	130.4x51x93.9	6733	7350
SO 101 FA	8	115	3.78...12.06	134...426	3.78...12.06	134...426	75	100	4.77*	6.4	114.4x51x74.25	130.4x51x93.9	6777	7394
	10	150	4.07...10.46	144...369	4.07...10.46	144...369	75	100	4.77*	6.4	114.4x51x74.25	130.4x51x93.9	6777	7394
SO 126 FA	8	115	3.76...13.01	133...459	3.76...13.01	133...459	90	125	4.77*	6.4	114.4x51x77.1	130.4x51x96.8	7355	7972
	10	150	4.15...13.01	147...459	4.15...13.01	147...459	90	125	4.77*	6.4	114.4x51x77.1	130.4x51x96.8	7355	7972

\* Additionally there is an oil pump with a fan motor of 1.5 kW = 2 hp.

BOGE type	max. pressure		free air delivery**				motor power				dimensions silenced	weight silenced
			(50 Hz)		(60 Hz)		main drive		fan motor		W x D x H	lbs
			m³/min	cfm	m³/min	cfm	kW	hp	kW	hp	inch	
SO 61-2 W	8	115	7.05	249	7.02	248	45	60	0.55	0.75	110.6x51.7x78.7	4849
	10	150	5.57	197	5.40	191	45	60	0.55	0.75	110.6x51.7x78.7	4849
SO 76-2 W	8	115	9.13	323	8.68	307	55	75	0.55	0.75	110.6x51.7x78.7	5132
	10	150	7.84	277	7.92	280	55	75	0.55	0.75	110.6x51.7x78.7	5132
SO 101-2 W	8	115	12.30	435	12.23	432	75	100	0.55	0.75	110.6x51.7x78.7	5598
	10	150	10.67	377	10.09	357	75	100	0.55	0.75	110.6x51.7x78.7	5598
SO 126-2 W	8	115	13.27	469	13.18	466	90	125	0.55	0.75	110.6x51.7x78.7	5778
	10	150	13.14	464	12.31	435	90	125	0.55	0.75	110.6x51.7x78.7	5778
SO 61-2 FW	8	115	2.62...7.05	93...249	2.62...7.05	93...249	45	60	0.55	0.75	110.6x51.7x78.7	5238
	10	150	3.34...5.57	118...197	3.34...5.57	118...197	45	60	0.55	0.75	110.6x51.7x78.7	5238
SO 76-2 FW	8	115	2.84...9.13	100...323	2.84...9.13	100...323	55	75	0.55	0.75	110.6x51.7x78.7	5769
	10	150	3.25...7.84	114...277	3.25...7.84	114...277	55	75	0.55	0.75	110.6x51.7x78.7	5769
SO 101-2 FW	8	115	3.65...12.30	129...435	3.65...12.30	129...435	75	100	0.55	0.75	110.6x51.7x78.7	5946
	10	150	4.02...10.67	142...377	4.02...10.67	142...377	75	100	0.55	0.75	110.6x51.7x78.7	5946
SO 126-2 FW	8	115	3.86...13.27	136...469	3.86...13.27	136...469	90	125	0.55	0.75	110.6x51.7x78.7	5979
	10	150	4.02...13.14	142...464	4.02...13.14	142...464	90	125	0.55	0.75	110.6x51.7x78.7	5979

\*\* Free air delivery for the complete package in accordance with ISO 1217, Appendix C, at 20°C ambient temperature and maximum pressure. Emitted sound level as per DIN EN ISO 2151 from 70 dB(A). The technical data is designed for international use: maximum ambient temperature + 40°C, maximum cooling water temperature + 40°C. Different demands on request. Dimensions and construction are subject to change.

# SO 150-2 to SO 480-2 – water cooled oil-free screw compressors



Free air delivery: 16.20 – 51.49 m<sup>3</sup>/min, 572 – 1818 cfm

Pressure range: 8 – 10 bar, 115 – 150 psig

Motor range: 110 – 355 kW, 150 – 480 HP



## EXTREMELY QUIET

The SO-2 machines are equipped with a combined sound and pulsation absorber. Because of its intelligent design and the use of powerful sound absorbing materials the entire range operates quieter than ever before.



## HIGHEST EFFICIENCY

The cooling air flow of the SO-2 machines has been substantially optimised. The air intake from the coolest area and the minimisation of pressure losses additionally increase the free air delivery with a low specific power consumption.



## SAFE AND SERVICE FRIENDLY

Particular importance was given to optimise accessibility of maintenance intensive components (e.g. cooler and oil cooler) during the design of the SO-2 machines. An additional separator was integrated to improve intermediate separation – for absolutely safe operation.



## FLEXIBLY CONNECTING

The raised position of the compressed air outlet does not require any risers and allows for problem free connection of additional components: e.g. external aftercooler, cyclone separator, filters and dryers.

**Oil-free compressed air at the highest level: The SO-2 generation of oil-free screw compressors sets new standards in the 110 and 355 kW performance class. High FADs, low specific power consumption, extremely quiet operation along with the service friendly design are the benchmarks of this series – for oil-free compressed air production at a superior level!**

BOGE Model	max. pressure		free air delivery*				motor power				dimensions super-silenced W x D x H inch	weight super-silenced lbs
	bar	psig	(50 Hz)		(60 Hz)		main drive		fan motor			
			m <sup>3</sup> /min	cfm	m <sup>3</sup> /min	cfm	kW	hp	kW	hp		
SO 150-2 W	8	115	18.57	656	17.03	601	110	150	0.75	1.0	127.2x59.8x71.7	7275
	10	150	16.20	572	16.93	598	110	150	0.75	1.0		
SO 180-2 W	8	115	21.60	763	22.33	789	132	180	0.75	1.0	127.2x59.8x71.7	7385
	10	150	19.60	692	19.86	701	132	180	0.75	1.0		
SO 220-2 W	8	115	26.30	929	26.29	928	160	220	0.75	1.0	127.2x59.8x71.7	7496
	10	150	23.20	819	23.89	844	160	220	0.75	1.0		
SO 269-2 W	10	150	26.18	925	26.17	924	200	270	0.75	1.0	127.2x59.8x71.7	7937
SO 270-2 W	8	115	34.90	1232	33.43	1181	200	270	1.1	1.5	148.8x70.9x84.6	11464
	10	150	28.40	1003	29.40	1038	200	270	1.1	1.5		
SO 340-2 W	8	115	42.36	1496	43.13	1523	250	340	1.1	1.5	148.8x70.9x84.6	11905
	10	150	35.92	1269	36.27	1281	250	340	1.1	1.5		
SO 430-2 W	8	115	47.22	1668	46.03	1626	315	430	1.1	1.5	148.8x70.9x84.6	12236
	10	150	46.89	1656	45.95	1623	315	430	1.1	1.5		
SO 431-2 W	8	115	51.49	1818	50.96	1800	315	430	1.1	1.5	148.8x70.9x84.6	12236
SO 480-2 W	10	150	51.41	1816	50.89	1797	355	480	1.1	1.5	148.8x70.9x84.6	12566

\* Free air delivery for the complete package in accordance with ISO 1217, Appendix C, at 20°C ambient temperature and maximum pressure. Emitted sound level as per DIN EN ISO 2151 from 70 dB(A). The technical data is designed for international use: maximum ambient temperature + 40°C, maximum cooling water temperature + 40°C. Different demands on request. Dimensions and construction are subject to change.

**BOGE COMPRESSORS**

**BOGE AMERICA, INC.**

3414 Florence Circle

Suite 100 · Powder Springs, GA 30127

Tel. 770-874-1570 · Fax. 770-874-1571

www.boge.com · usa@boge.com

# **B**est **O**f **G**erman **E**ngineering

In more than 120 countries worldwide customers from mechanical engineering, industry and trade trust the BOGE know-how in planning, development and production of high quality compressed air systems. Already in its fourth generation, the family-owned company puts all its experience in the development of innovative solutions and outstanding efficient products for the compressed air industry.

Rightly, therefore, the last name of the founder Otto Boge stands for „Best Of German Engineering“ today. Who puts emphasis on German engineering skills, highest safety, reliable services and energy efficiency, accesses quality products from BOGE because they have been supplying „the air to work“ for more than 100 years.

**OUR RANGES OF SERVICES INCLUDE THE FOLLOWING:**

- Energy efficient systems development
- Plant design and engineering
- Industry 4.0 solutions, system control and visualisation
- High Speed Turbo compressors
- Oil-free piston, screw and scroll compressors
- Oil injected screw compressors and oil lubricated piston compressors
- Compressed air treatment
- Compressed air distribution and storage
- Compressed air accessories
- Compressed air service
- Nitrogen and oxygen generators

